

# PANTA REI

## TELESCOPICO TELE T / TELESCOPIC TELE-T (PRTT3-80 PRTT3-100)

### ISTRUZIONI DI MONTAGGIO / ASSEMBLY INSTRUCTIONS

#### SENZA VETRO FISSO / WITHOUT FIXED GLASS

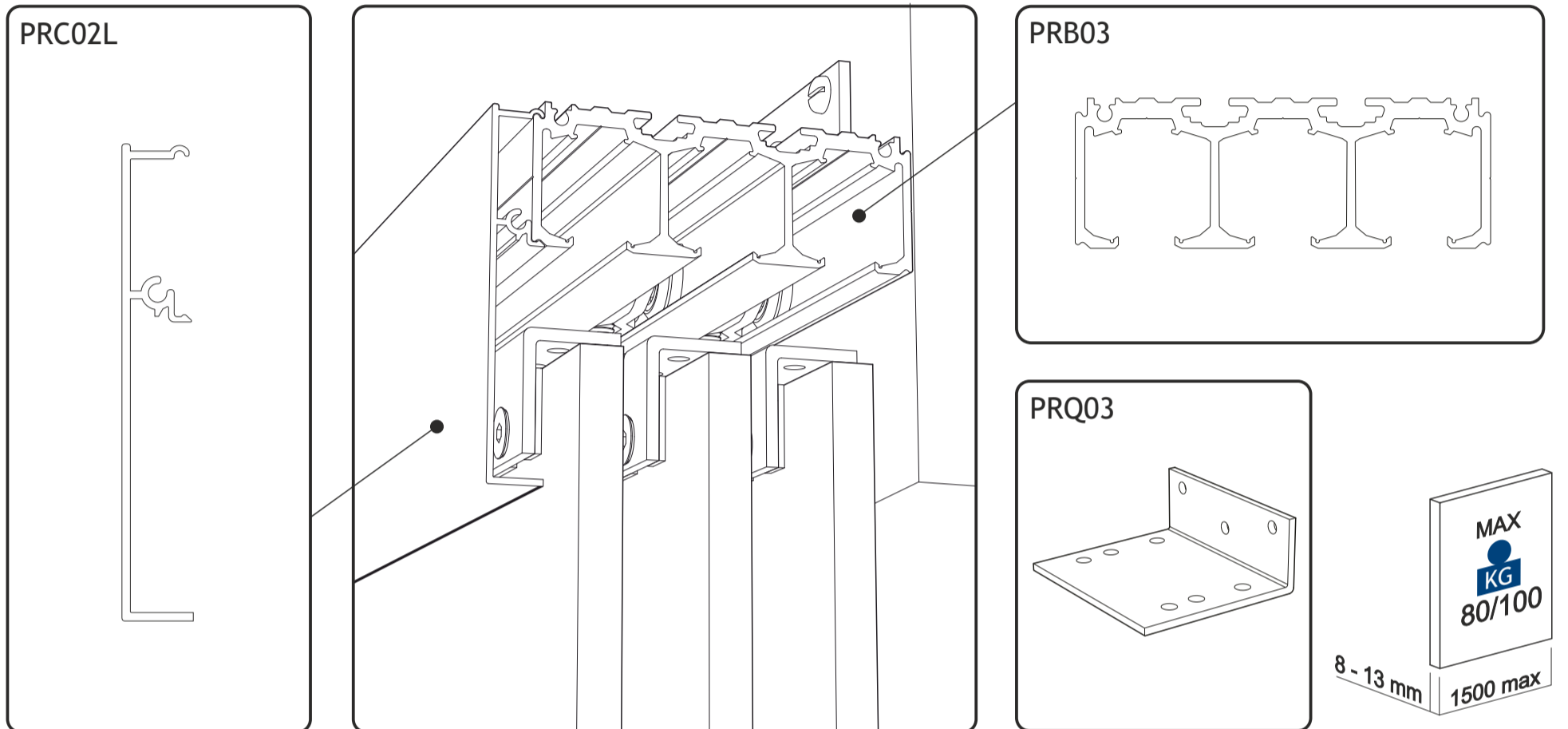

#### CON VETRO FISSO / WITH FIXED GLASS

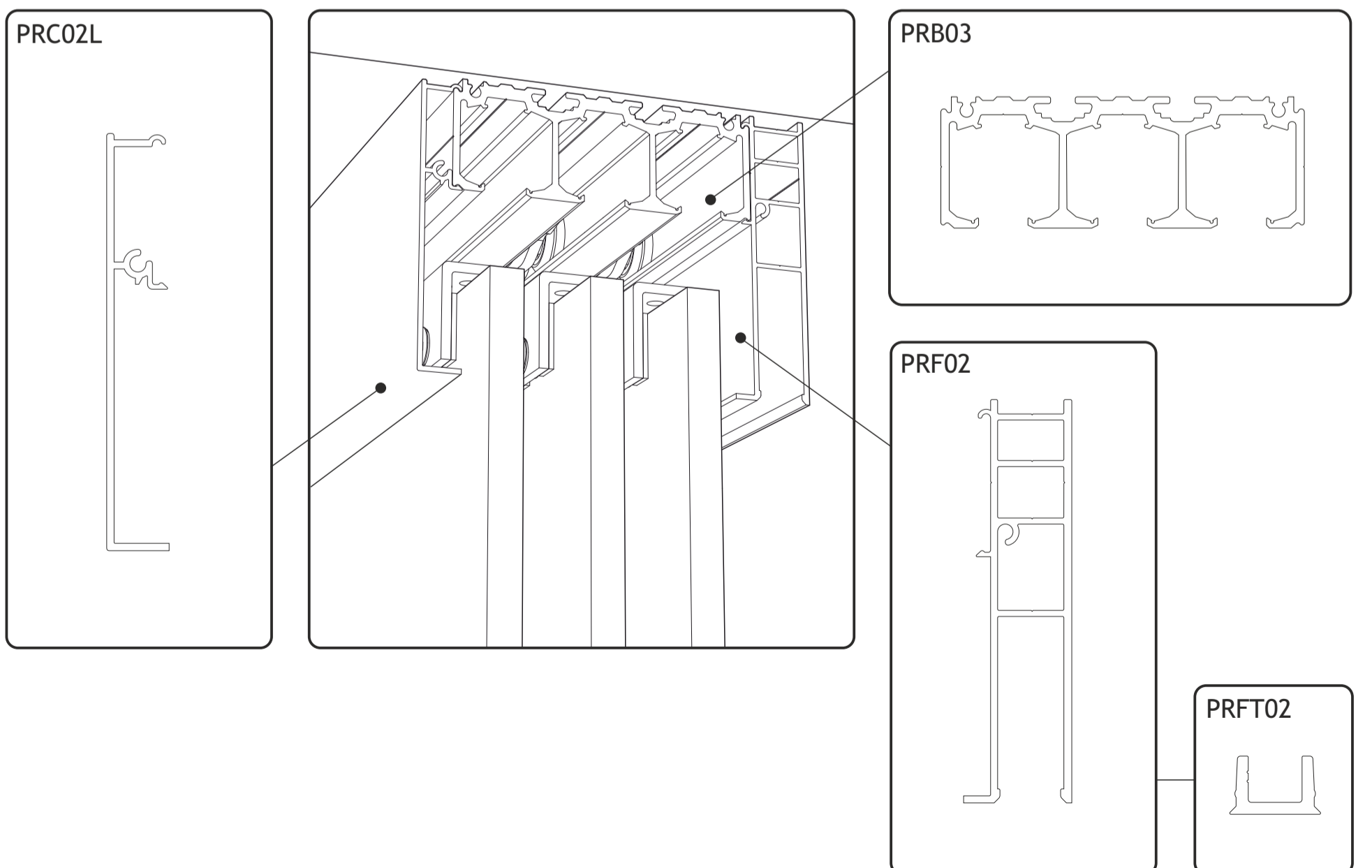

**PRTT3-80 PANTA REI TELE-T KIT A 3 ANTE TELESCOPICHE / 3 TELESCOPIC LEAFS**

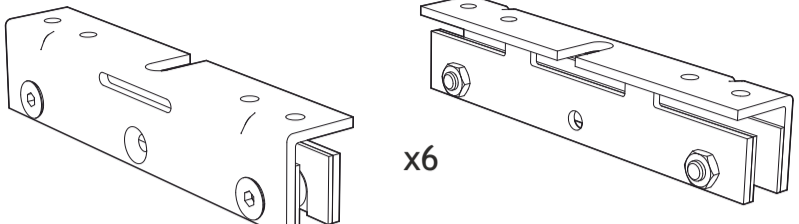
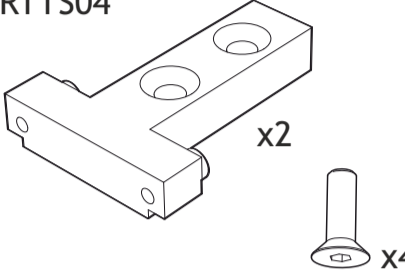
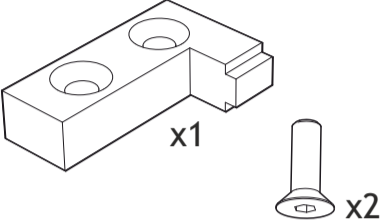
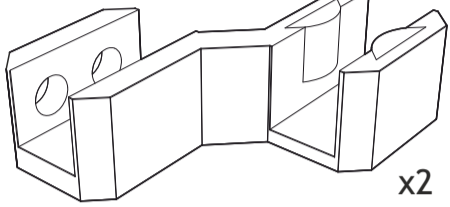
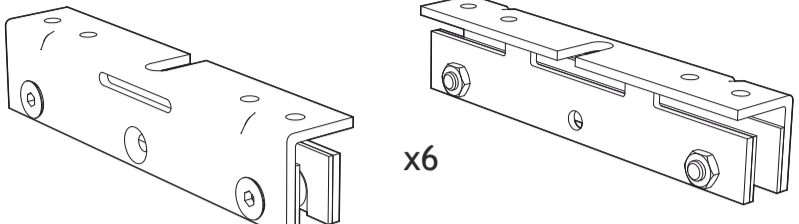
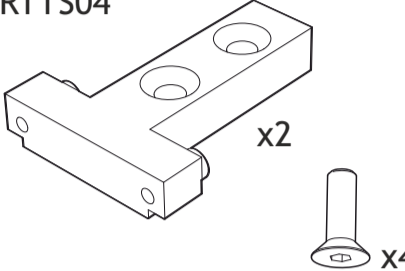
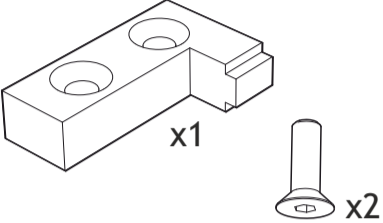
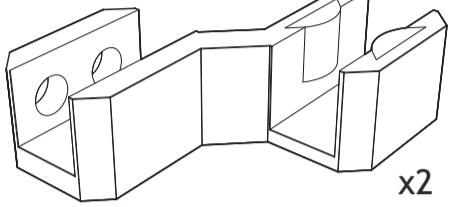
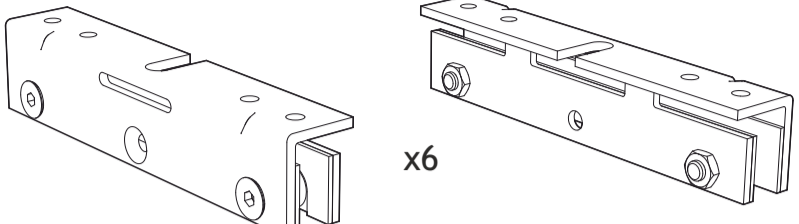
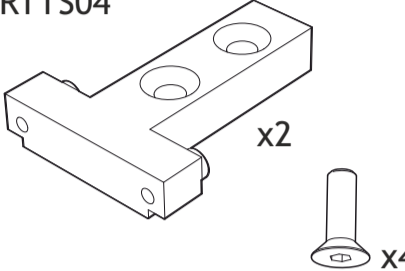
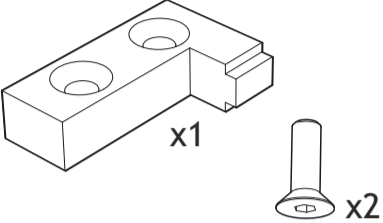
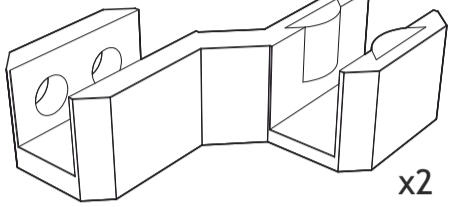
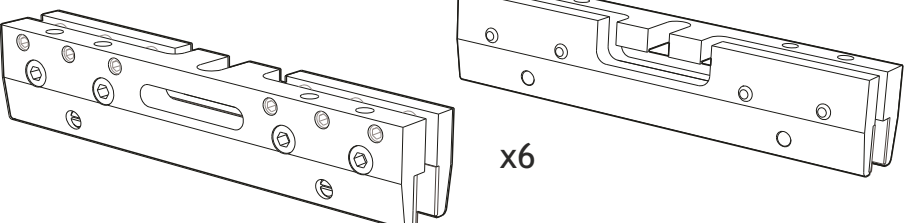
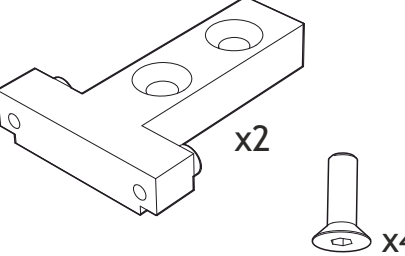
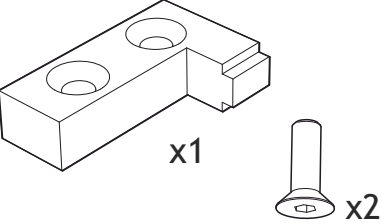
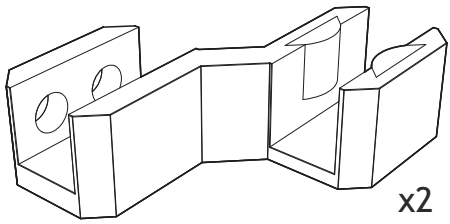
<p>SD03</p>  <p>x6</p>	<p>PRTT504</p>  <p>x2</p> <p>x4</p>	<p>PRTT502</p>  <p>x1</p> <p>x2</p>	<p>SDZ01</p>  <p>x2</p>	<p>SD03</p>  <p>x6</p>	<p>PRTT504</p>  <p>x2</p> <p>x4</p>	<p>PRTT502</p>  <p>x1</p> <p>x2</p>	<p>SDZ01</p>  <p>x2</p>
<p>SD03</p>  <p>x6</p>	<p>PRTT504</p>  <p>x2</p> <p>x4</p>	<p>PRTT502</p>  <p>x1</p> <p>x2</p>	<p>SDZ01</p>  <p>x2</p>	<p>SD07</p>  <p>x6</p>	<p>PRTT504</p>  <p>x2</p> <p>x4</p>	<p>PRTT502</p>  <p>x1</p> <p>x2</p>	<p>SDZ01</p>  <p>x2</p>

**PRTT3-100 PANTA REI TELE-T KIT 3 ANTE TELESCOPICHE / 3 TELESCOPIC LEAFS**

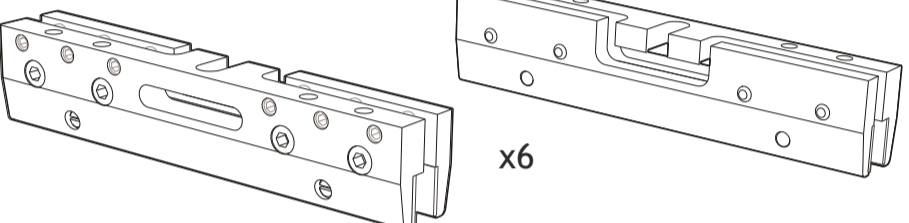
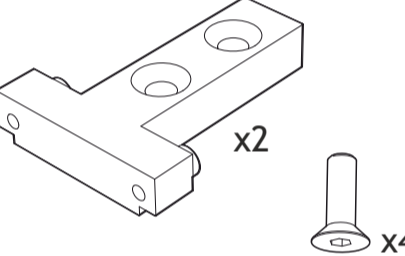
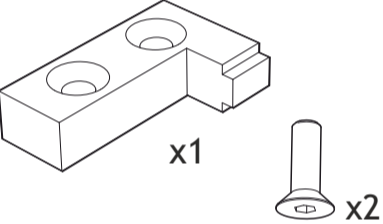
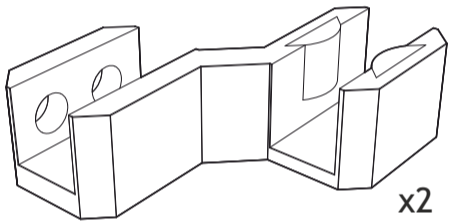
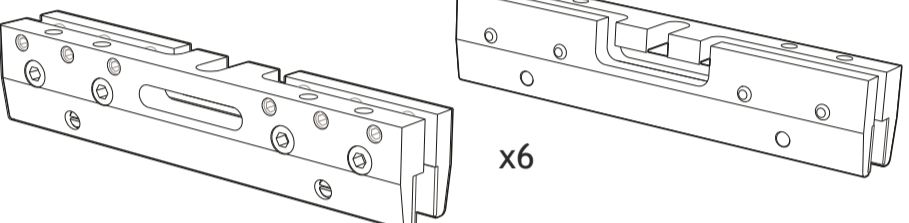
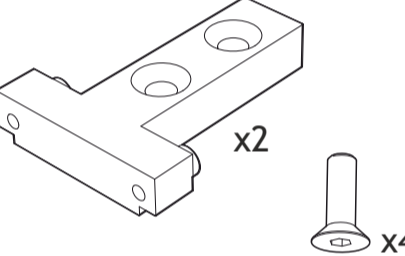
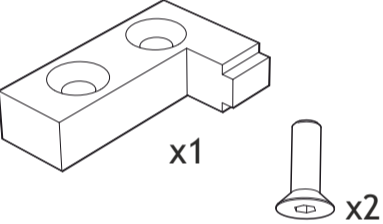
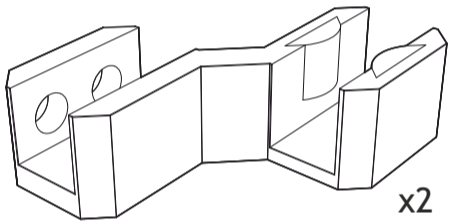
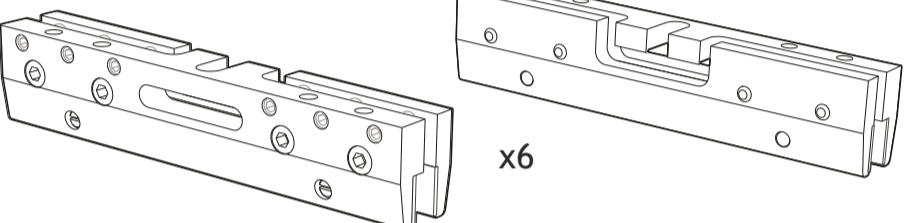
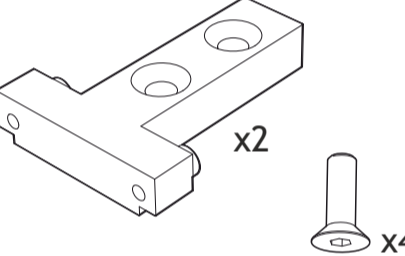
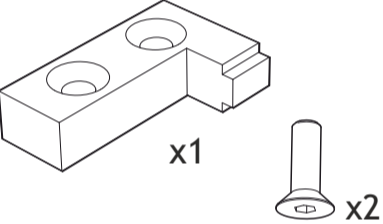
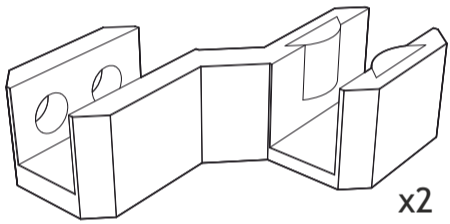
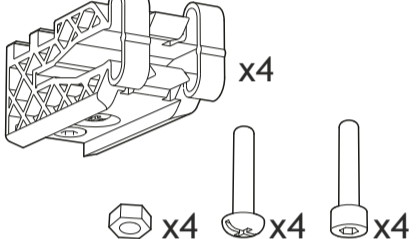
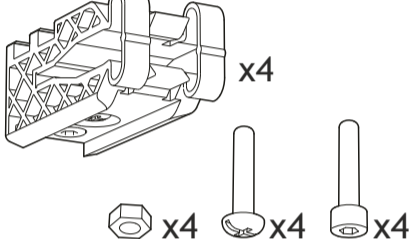
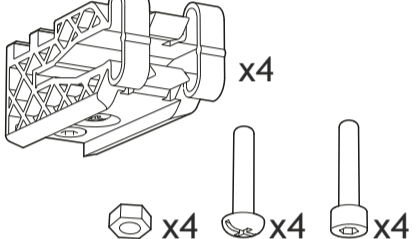
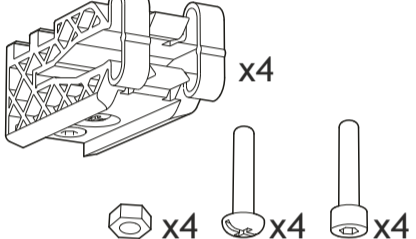
<p>SD07</p>  <p>x6</p>	<p>PRTT504</p>  <p>x2</p> <p>x4</p>	<p>PRTT502</p>  <p>x1</p> <p>x2</p>	<p>SDZ01</p>  <p>x2</p>	<p>SD07</p>  <p>x6</p>	<p>PRTT504</p>  <p>x2</p> <p>x4</p>	<p>PRTT502</p>  <p>x1</p> <p>x2</p>	<p>SDZ01</p>  <p>x2</p>
<p>SD07</p>  <p>x6</p>	<p>PRTT504</p>  <p>x2</p> <p>x4</p>	<p>PRTT502</p>  <p>x1</p> <p>x2</p>	<p>SDZ01</p>  <p>x2</p>	<p>STOPPER PR2207</p>  <p>x4</p> <p>x4</p> <p>x4</p> <p>x4</p>	<p>STOPPER PR2207</p>  <p>x4</p> <p>x4</p> <p>x4</p> <p>x4</p>	<p>STOPPER PR2207</p>  <p>x4</p> <p>x4</p> <p>x4</p> <p>x4</p>	<p>STOPPER PR2207</p>  <p>x4</p> <p>x4</p> <p>x4</p> <p>x4</p>

**A PARETE / TO WALL**

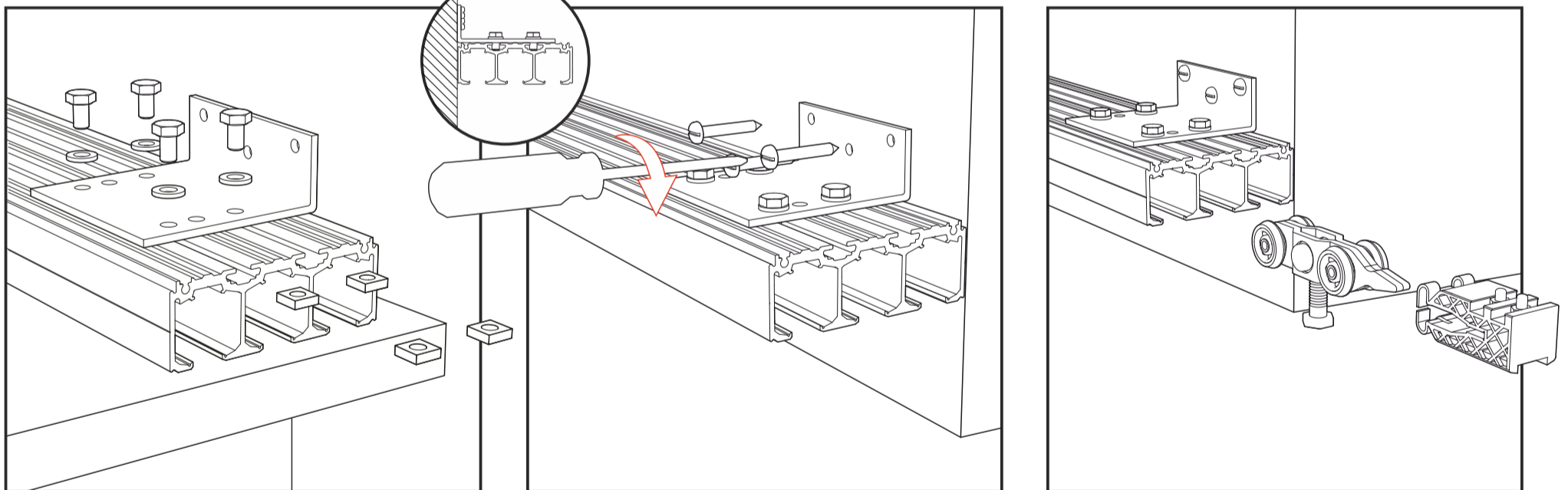

**A SOFFITTO / TO CEILING**

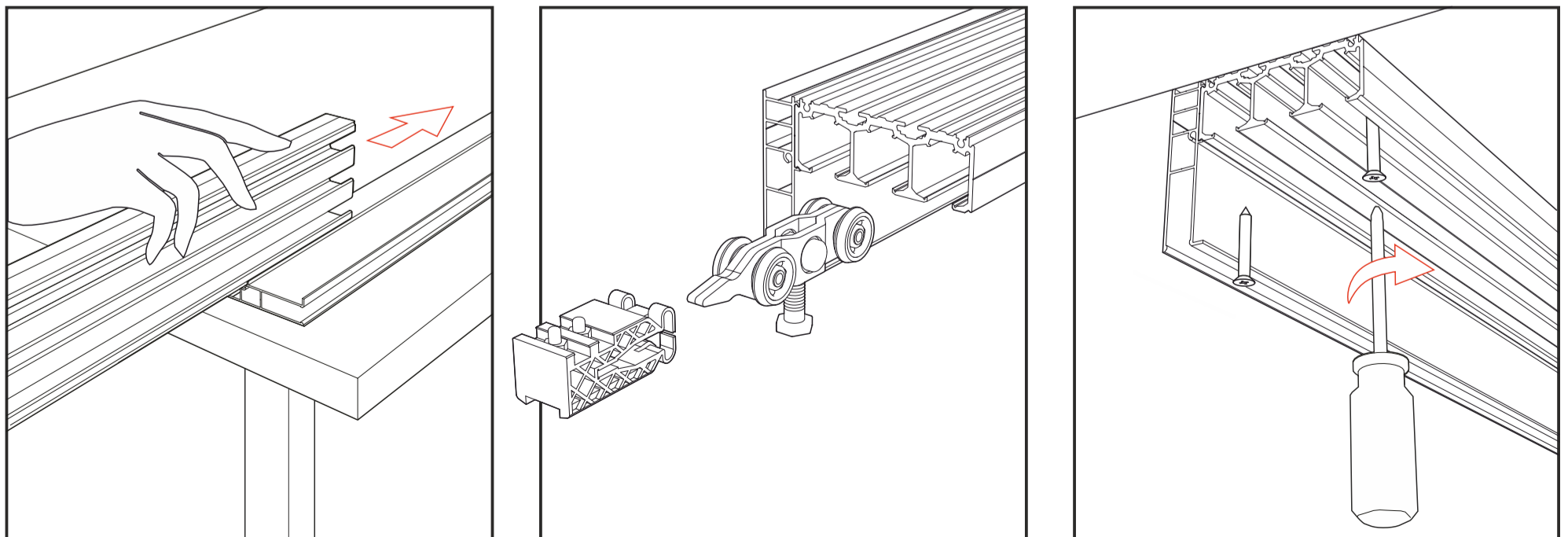

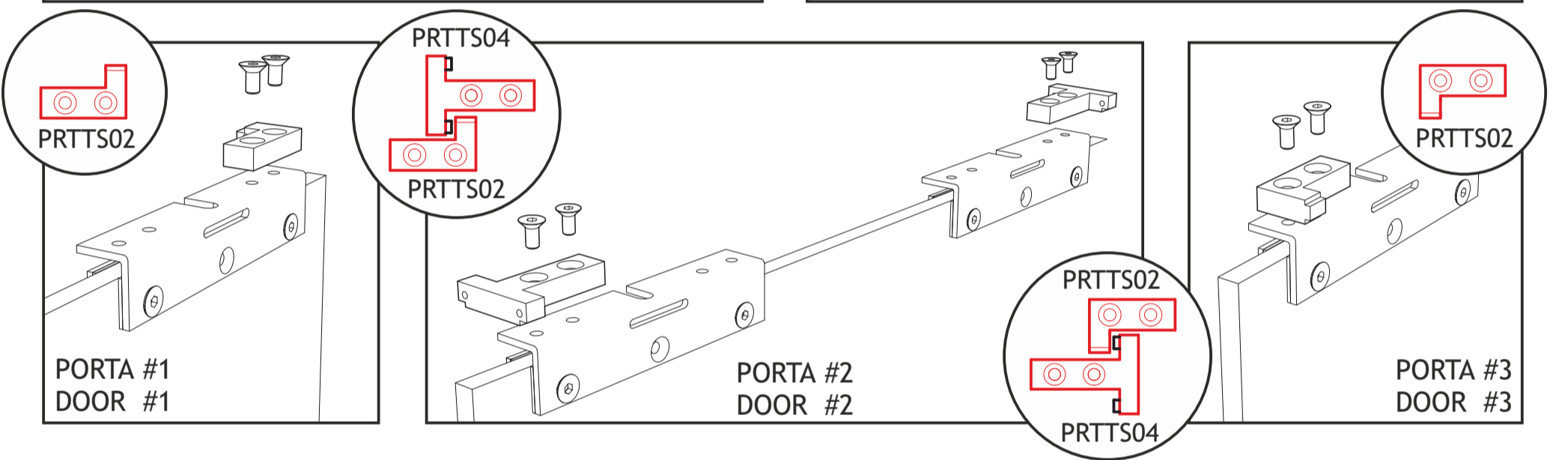
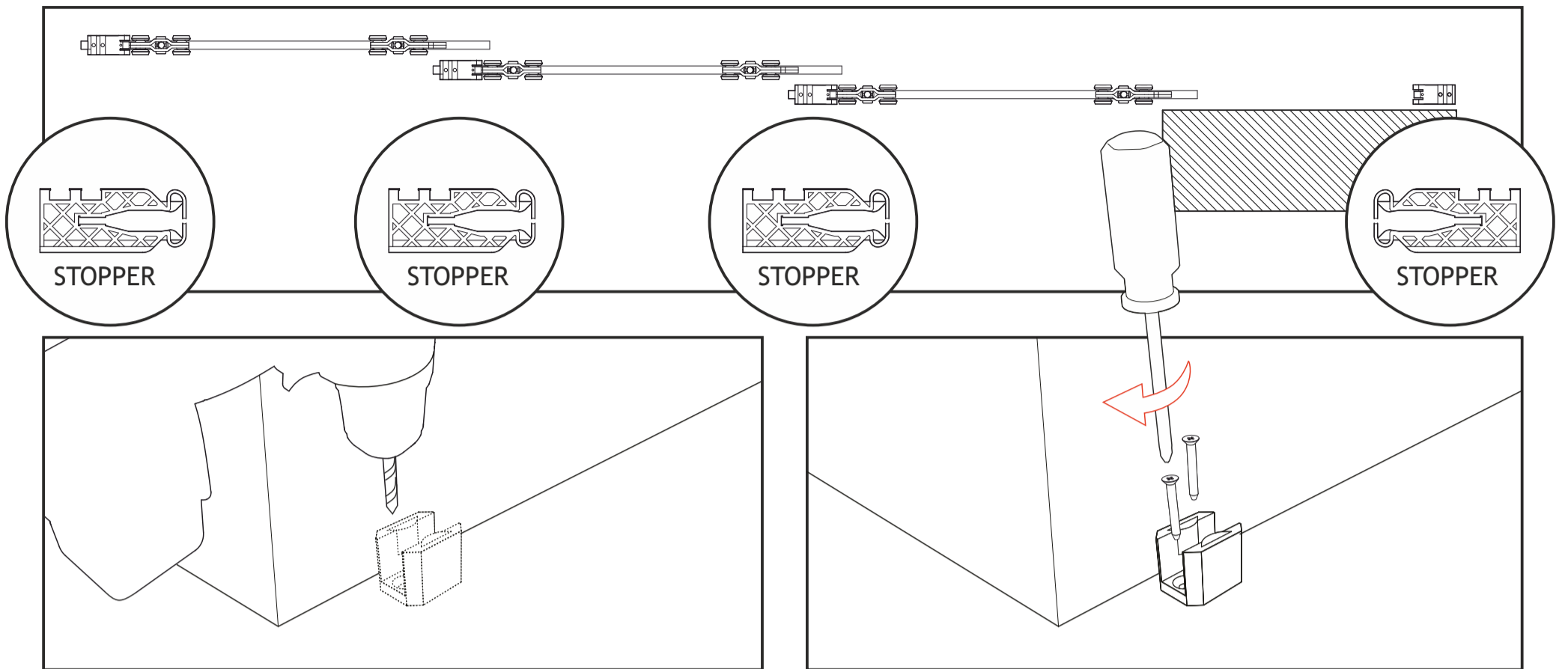

**PER SD07  
FOR SD07**

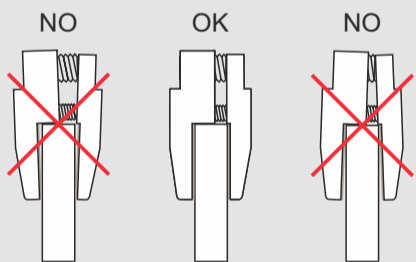

**IMPORTANTE:** durante l'installazione delle pinze verificare che le ganasce siano sempre complanari alla superficie del vetro come rappresentato nella figura centrale.

**IMPORTANT:** during the installation of the clamps, the jaws must be always coplanar to the glass surface as shown in the central figure.

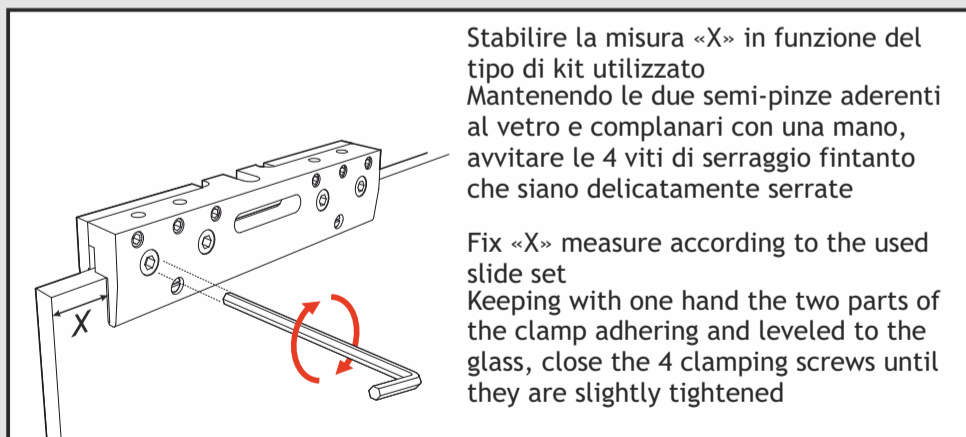

Stabilire la misura «X» in funzione del tipo di kit utilizzato  
Mantenendo le due semi-pinze aderenti al vetro e complanari con una mano, avvitare le 4 viti di serraggio fintanto che siano delicatamente serrate

Fix «X» measure according to the used slide set  
Keeping with one hand the two parts of the clamp adhering and leveled to the glass, close the 4 clamping screws until they are slightly tightened

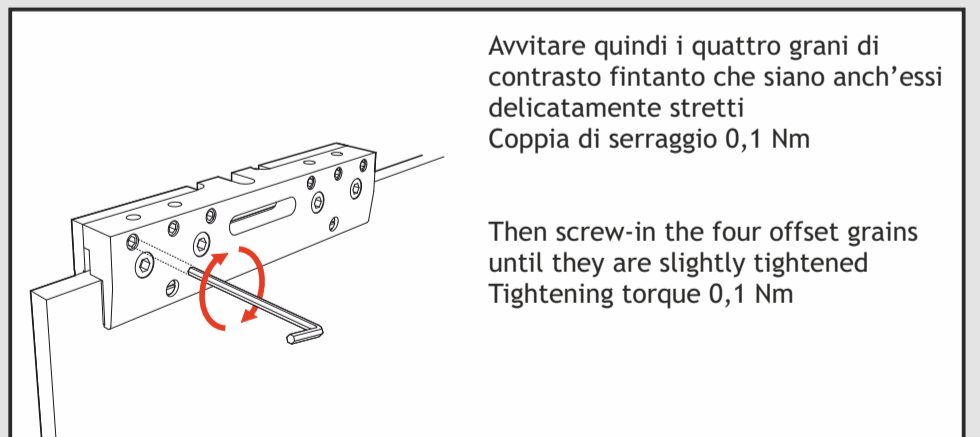

Avvitare quindi i quattro grani di contrasto fintanto che siano anch'essi delicatamente stretti  
Coppia di serraggio 0,1 Nm

Then screw-in the four offset grains until they are slightly tightened  
Tightening torque 0,1 Nm

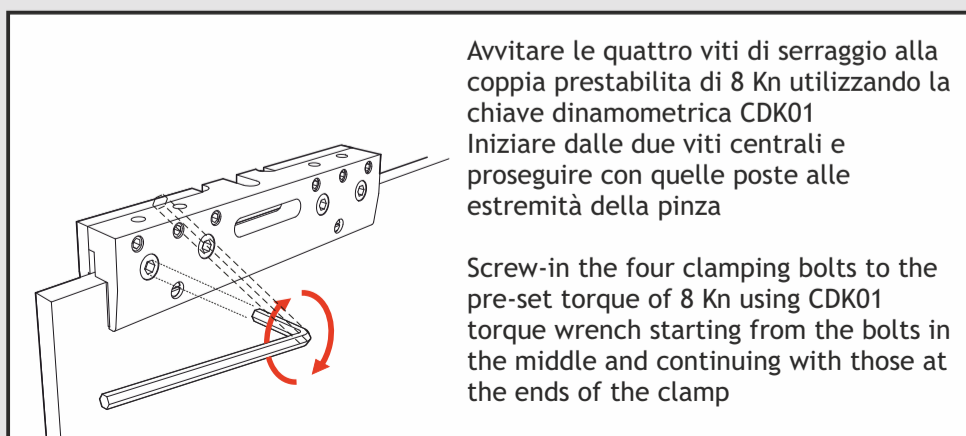

Avvitare le quattro viti di serraggio alla coppia prestabilita di 8 Kn utilizzando la chiave dinamometrica CDK01  
Iniziare dalle due viti centrali e proseguire con quelle poste alle estremità della pinza

Screw-in the four clamping bolts to the pre-set torque of 8 Kn using CDK01 torque wrench starting from the bolts in the middle and continuing with those at the ends of the clamp

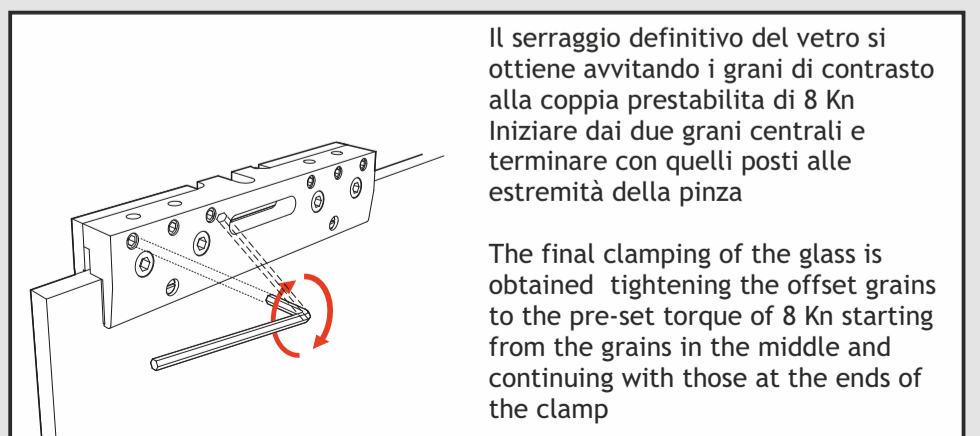

Il serraggio definitivo del vetro si ottiene avvitando i grani di contrasto alla coppia prestabilita di 8 Kn  
Iniziare dai due grani centrali e terminare con quelli posti alle estremità della pinza

The final clamping of the glass is obtained tightening the offset grains to the pre-set torque of 8 Kn starting from the grains in the middle and continuing with those at the ends of the clamp



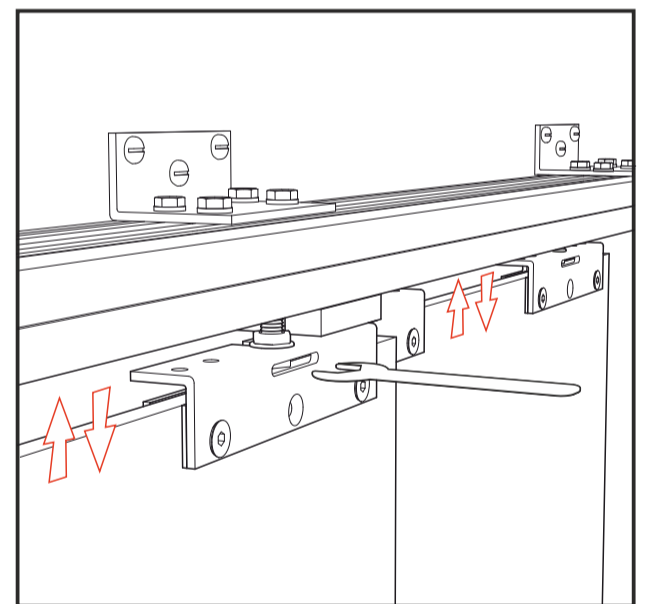
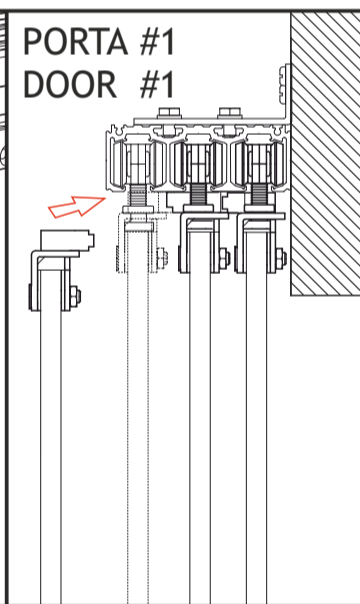
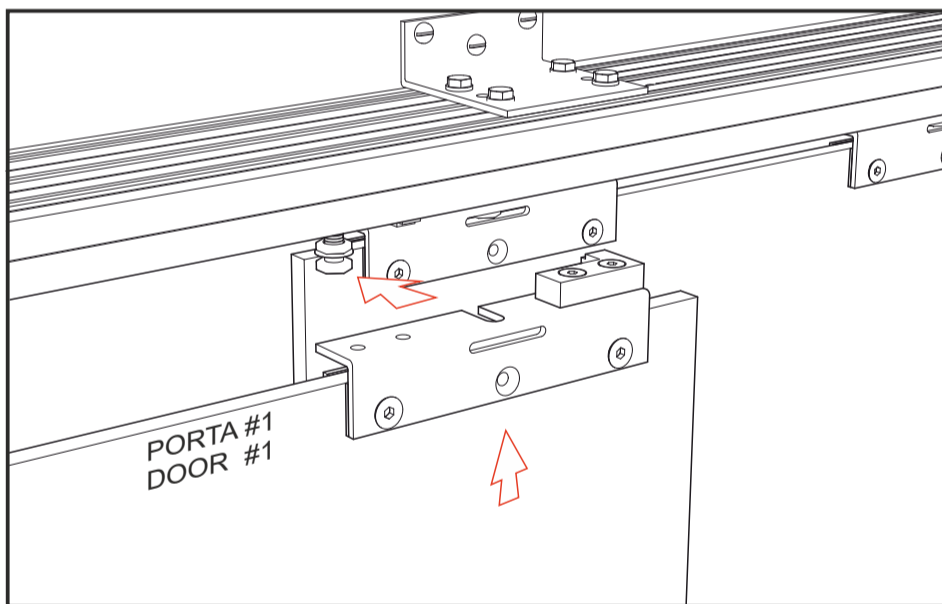
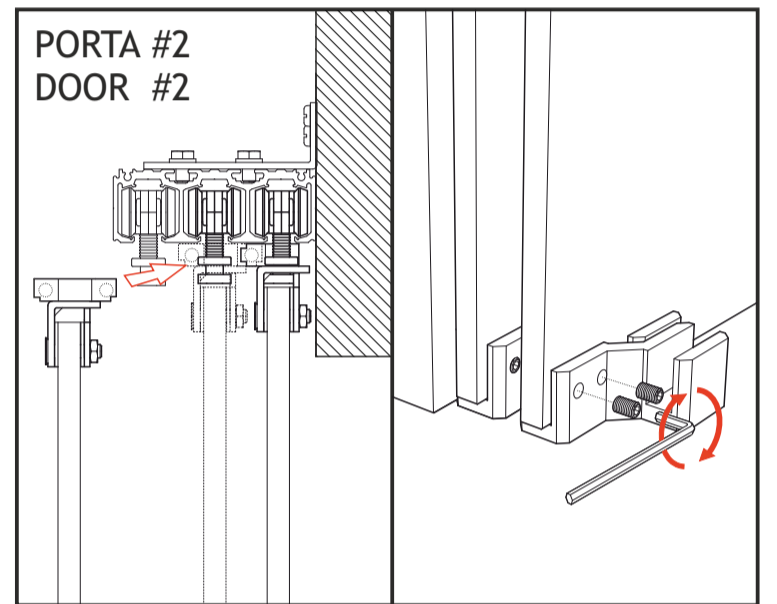
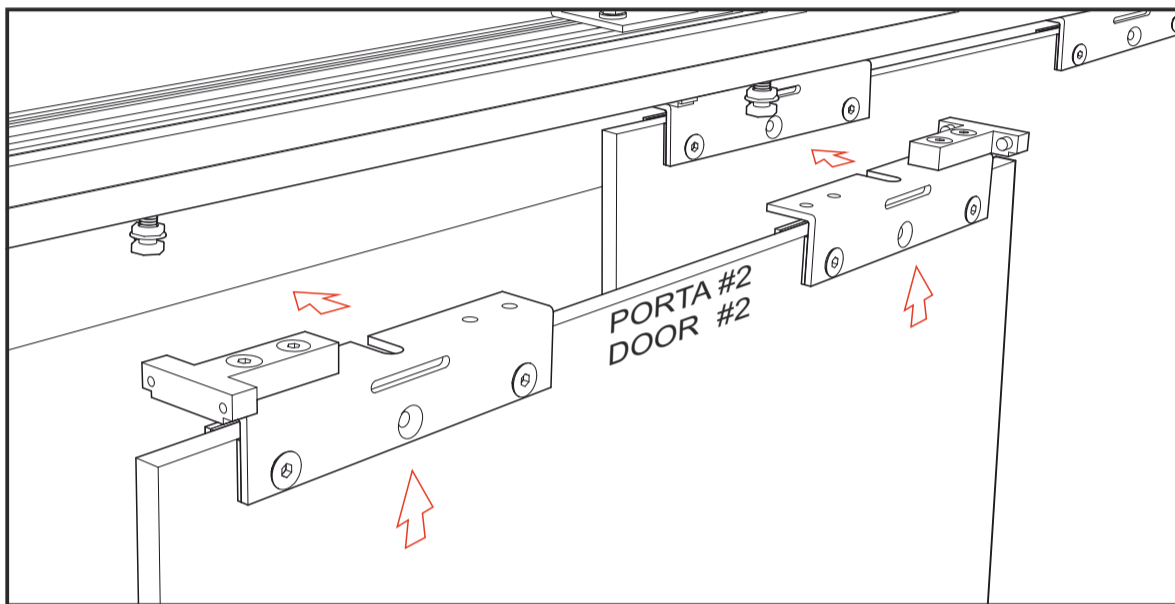
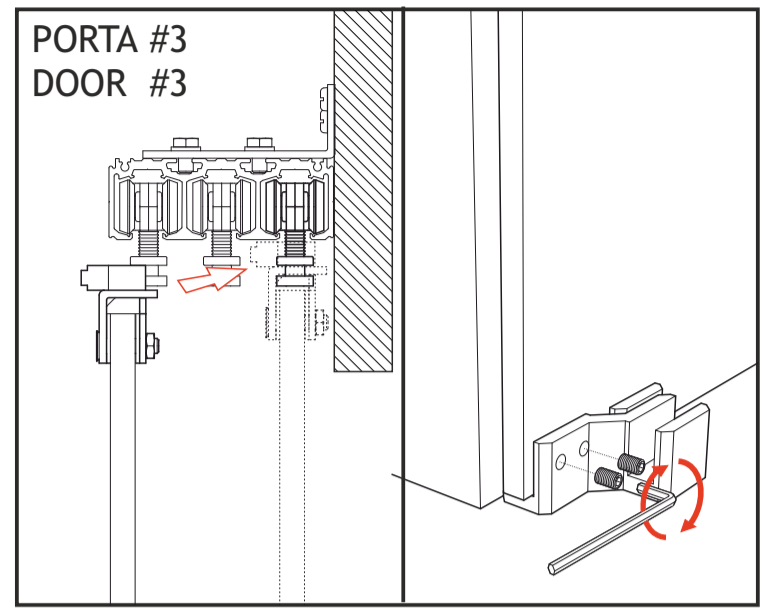
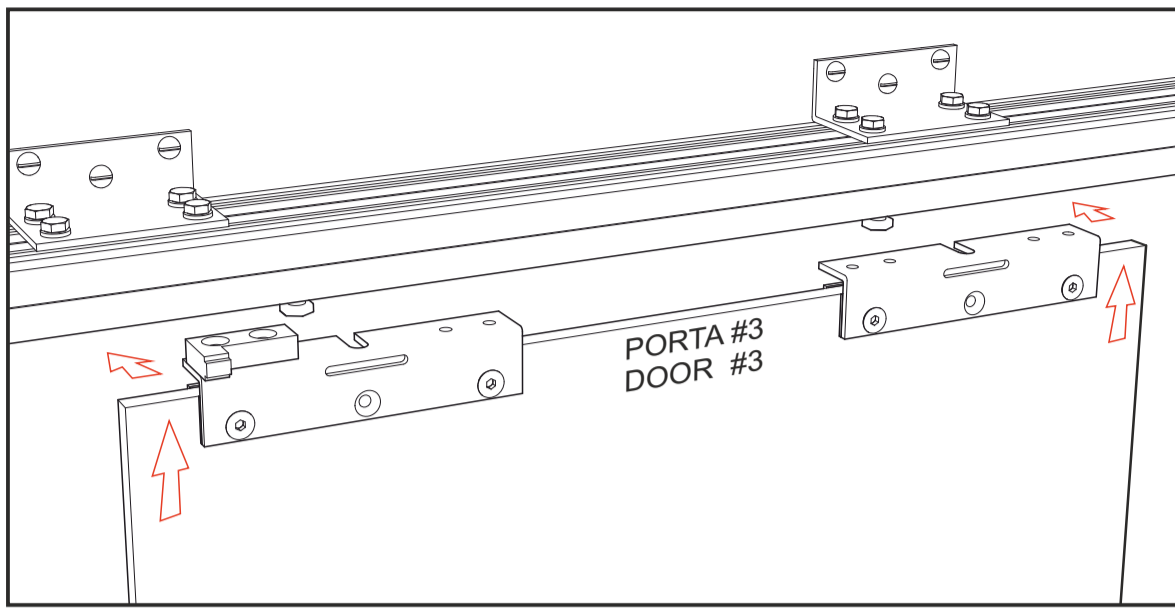

**SENZA FISSO / WITHOUT FIXED GLASS**

**CON FISSO / WITH FIXED GLASS**

